

Block: MAIN
 Author:
 Created: 04/05/2007 10:09:32 am
 Last Modified: 05/29/2007 01:37:21 pm

Symbol	Var Type	Data Type	Comment
	TEMP		
	TEMP		
	TEMP		
	TEMP		

PROGRAM COMMENTS

Network 1 Network Title

OPROEP ASI

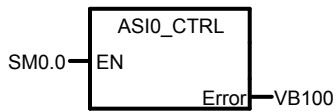

Network 2

INDIEN ER EEN BLOKJE VOOR SENSOR STAAT MAG CILINDER NIET INSCHUIVEN

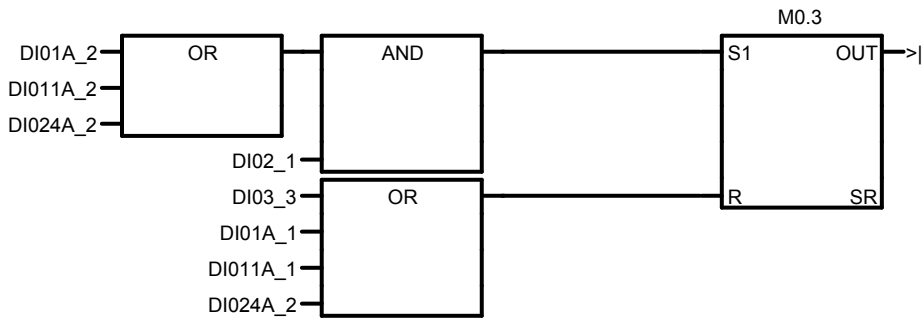

Symbol	Address	Comment
DI011A_1	V5.0	Symbol Input 1:Slave 11A - Digital (4I/3Q (AB 7Hex))
DI011A_2	V5.1	Symbol Input 2:Slave 11A - Digital (4I/3Q (AB 7Hex))
DI01A_1	V0.0	Symbol Input 1:Slave 1A - Digital (4I/3Q (AB 7Hex))
DI01A_2	V0.1	Symbol Input 2:Slave 1A - Digital (4I/3Q (AB 7Hex))
DI024A_2	V12.5	Symbol Input 2:Slave 24A - Digital (4I/3Q (AB 7Hex))
DI02_1	V1.4	Symbol Input 1:Slave 2 - Digital (3I/1Q (St 1Hex))
DI03_3	V1.2	Symbol Input 3:Slave 3 - Digital (4I/4Q (St 7Hex))

Network 3

START STOP van de 3 eilanden + 3 controlelampen die branden + V27.0 is het druk3/2 ventiel eiland 3

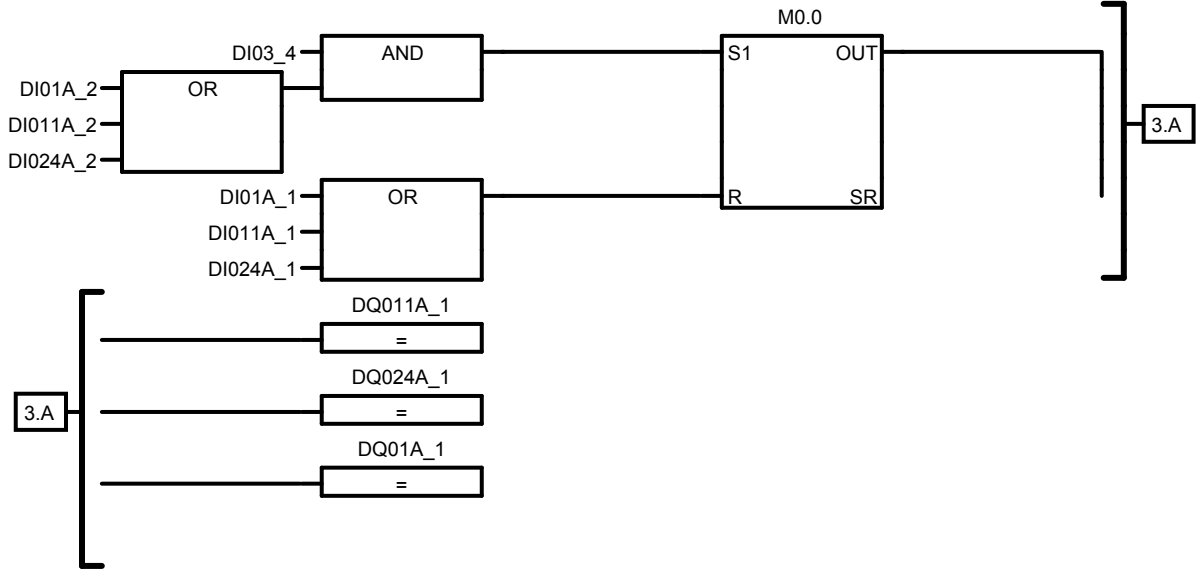

Symbol	Address	Comment
DI011A_1	V5.0	Symbol Input 1:Slave 11A - Digital (4I/3Q (AB 7Hex))
DI011A_2	V5.1	Symbol Input 2:Slave 11A - Digital (4I/3Q (AB 7Hex))
DI01A_1	V0.0	Symbol Input 1:Slave 1A - Digital (4I/3Q (AB 7Hex))
DI01A_2	V0.1	Symbol Input 2:Slave 1A - Digital (4I/3Q (AB 7Hex))
DI024A_1	V12.4	Symbol Input 1:Slave 24A - Digital (4I/3Q (AB 7Hex))
DI024A_2	V12.5	Symbol Input 2:Slave 24A - Digital (4I/3Q (AB 7Hex))
DI03_4	V1.3	Symbol Input 4:Slave 3 - Digital (4I/4Q (St 7Hex))
DQ011A_1	V21.0	Symbol Output 1:Slave 11A - Digital (4I/3Q (AB 7Hex))
DQ01A_1	V16.0	Symbol Output 1:Slave 1A - Digital (4I/3Q (AB 7Hex))
DQ024A_1	V28.4	Symbol Output 1:Slave 24A - Digital (4I/3Q (AB 7Hex))

Network 4

STOPPEN VAN DE SCHAKELING WAARBIJ DE ARM STEEDS NAAR DE TRANSPORTBAND MOET BEWEGEN

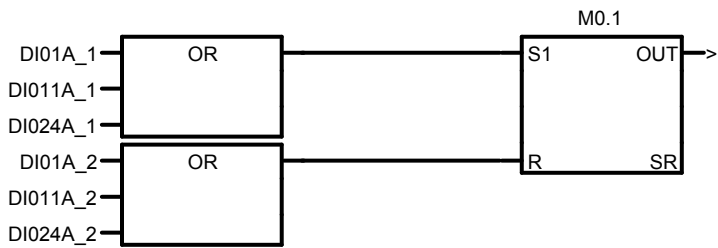

Symbol	Address	Comment
DI011A_1	V5.0	Symbol Input 1:Slave 11A - Digital (4I/3Q (AB 7Hex))
DI011A_2	V5.1	Symbol Input 2:Slave 11A - Digital (4I/3Q (AB 7Hex))
DI01A_1	V0.0	Symbol Input 1:Slave 1A - Digital (4I/3Q (AB 7Hex))
DI01A_2	V0.1	Symbol Input 2:Slave 1A - Digital (4I/3Q (AB 7Hex))
DI024A_1	V12.4	Symbol Input 1:Slave 24A - Digital (4I/3Q (AB 7Hex))
DI024A_2	V12.5	Symbol Input 2:Slave 24A - Digital (4I/3Q (AB 7Hex))

Network 5

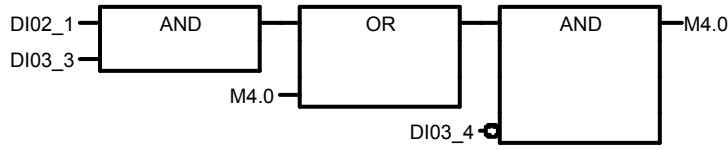

Symbol	Address	Comment
DI02_1	V1.4	Symbol Input 1:Slave 2 - Digital (3I/1Q (St 1Hex))
DI03_3	V1.2	Symbol Input 3:Slave 3 - Digital (4I/4Q (St 7Hex))
DI03_4	V1.3	Symbol Input 4:Slave 3 - Digital (4I/4Q (St 7Hex))

Network 6

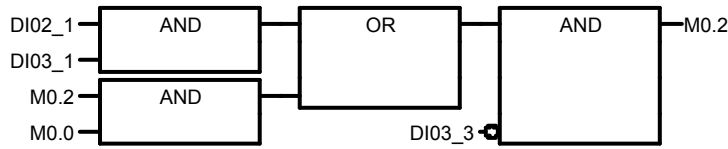

Symbol	Address	Comment
DI02_1	V1.4	Symbol Input 1:Slave 2 - Digital (3I/1Q (St 1Hex))
DI03_1	V1.0	Symbol Input 1:Slave 3 - Digital (4I/4Q (St 7Hex))
DI03_3	V1.2	Symbol Input 3:Slave 3 - Digital (4I/4Q (St 7Hex))

Network 7

CILINDER BLOKJE PLAATSSEN

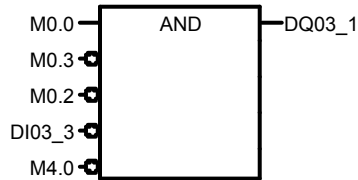

Symbol	Address	Comment
DI03_3	V1.2	Symbol Input 3:Slave 3 - Digital (4I/4Q (St 7Hex))
DQ03_1	V17.0	Symbol Output 1:Slave 3 - Digital (4I/4Q (St 7Hex))

Network 8

ARM NAAR LINKS OM BLOKJE TE NEMEN

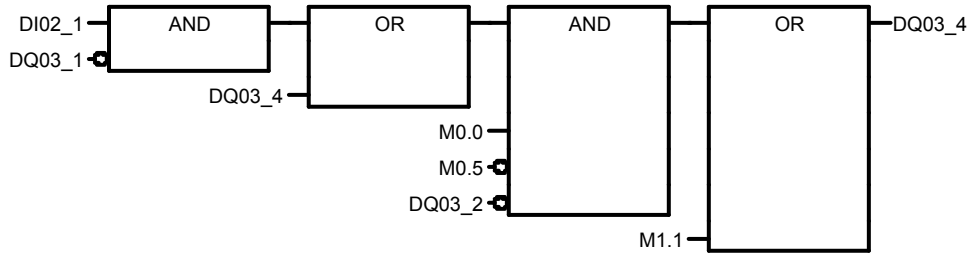

Symbol	Address	Comment
DI02_1	V1.4	Symbol Input 1:Slave 2 - Digital (3I/1Q (St 1Hex))
DQ03_1	V17.0	Symbol Output 1:Slave 3 - Digital (4I/4Q (St 7Hex))
DQ03_2	V17.1	Symbol Output 2:Slave 3 - Digital (4I/4Q (St 7Hex))
DQ03_4	V17.3	Symbol Output 4:Slave 3 - Digital (4I/4Q (St 7Hex))

Network 9

ARM TERUG NAAR RECHTS BIJ STOP. INDIEN HALVERWEGE EERST BLOKJE NEERZETTEN.

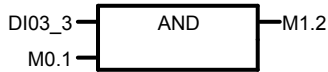

Symbol	Address	Comment
DI03_3	V1.2	Symbol Input 3:Slave 3 - Digital (4I/4Q (St 7Hex))

Network 10

ZUIGER AAN INDIEN ARM LINKS STAAT. ZUIGER UIT INDIEN ARM RECHTS STAAT

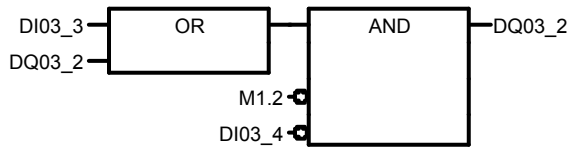

Symbol	Address	Comment
DI03_3	V1.2	Symbol Input 3:Slave 3 - Digital (4I/4Q (St 7Hex))
DI03_4	V1.3	Symbol Input 4:Slave 3 - Digital (4I/4Q (St 7Hex))
DQ03_2	V17.1	Symbol Output 2:Slave 3 - Digital (4I/4Q (St 7Hex))

Network 11

ARM NAAR RECHTS NA ZUIGER AAN OM BLOKJE TE PLAATSEN OP TRANSPORTBAND

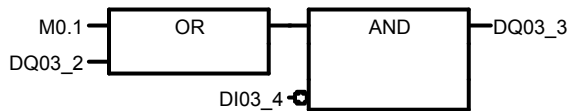

Symbol	Address	Comment
DI03_4	V1.3	Symbol Input 4:Slave 3 - Digital (4I/4Q (St 7Hex))
DQ03_2	V17.1	Symbol Output 2:Slave 3 - Digital (4I/4Q (St 7Hex))
DQ03_3	V17.2	Symbol Output 3:Slave 3 - Digital (4I/4Q (St 7Hex))

Network 12

2DE BLOKJE OP TRANSPORTBAND. MOTOR BLIJFT DRAAIEN EN ARM STAAT STIL. EERST 2 BLOKJES AFWERKEN VOOR ARM TERUG NAAR LINKS MAG GAAN.

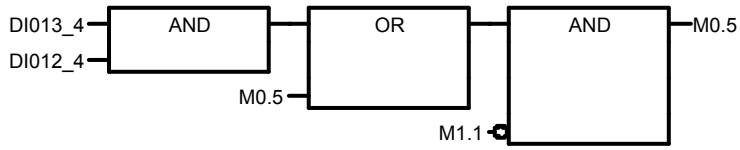

Symbol	Address	Comment
DI012_4	V6.7	Symbol Input 4:Slave 12 - Digital (2I/2Q (St BHex))
DI013_4	V6.3	Symbol Input 4:Slave 13 - Digital (2I/2Q (St BHex))

Network 13

MOTOR TRANSPORTBAND

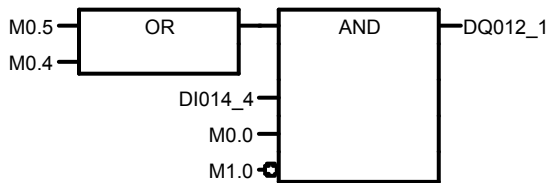

Symbol	Address	Comment
DI014_4	V7.7	Symbol Input 4:Slave 14 - Digital (2I/2Q (St BHex))
DQ012_1	V22.4	Symbol Output 1:Slave 12 - Digital (2I/2Q (St BHex))

Network 14

1STE BLOKJE OP TRANSPORTBAND TOT 2DE SENSOR. DAN MOTOR STOPPEN

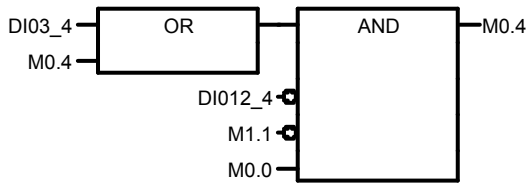

Symbol	Address	Comment
DI012_4	V6.7	Symbol Input 4:Slave 12 - Digital (2I/2Q (St BHex))
DI03_4	V1.3	Symbol Input 4:Slave 3 - Digital (4I/4Q (St 7Hex))

Network 15

CILINDER ANALOGE METING NAAR BOVEN V23.5 in plaats van 23.4

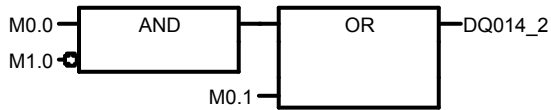

Symbol	Address	Comment
DQ014_2	V23.5	Symbol Output 2:Slave 14 - Digital (2I/2Q (St BHex))

Network 16

DETECTIE INDUCTIEVE SENSOR. Blokje moet verder naar einde transportband

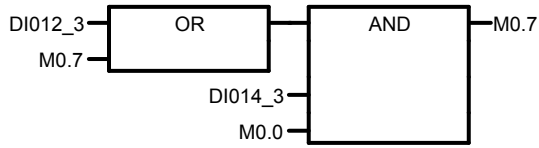

Symbol	Address	Comment
DI012_3	V6.6	Symbol Input 3:Slave 12 - Digital (2I/2Q (St BHex))
DI014_3	V7.6	Symbol Input 3:Slave 14 - Digital (2I/2Q (St BHex))

Network 17

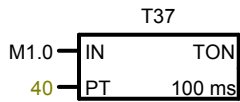

Network 18

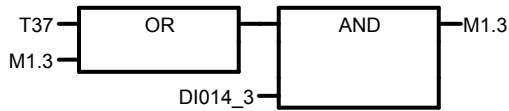

Symbol	Address	Comment
DI014_3	V7.6	Symbol Input 3:Slave 14 - Digital (2I/2Q (St BHex))

Network 19

TRANSPORTBAND STOPPEN EN CILINDER ANALOGE METING UIT

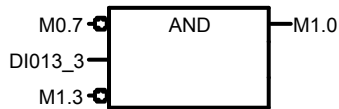

Symbol	Address	Comment
DI013_3	V6.2	Symbol Input 3:Slave 13 - Digital (2I/2Q (St BHex))

Network 20

Teller. 2 blokjes tellen daarna mag arm terug blokje nemen.

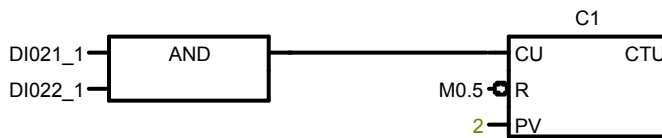

Symbol	Address	Comment
DI021_1	V10.0	Symbol Input 1:Slave 21 - Digital (4I/4Q (St 7Hex))
DI022_1	V11.4	Symbol Input 1:Slave 22 - Digital (4I/4Q (St 7Hex))

Network 21

Merker om arm blokje te laten nemen na counter C1

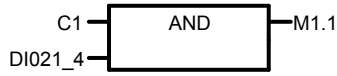

Symbol	Address	Comment
DI021_4	V10.3	Symbol Input 4:Slave 21 - Digital (4I/4Q (St 7Hex))

Network 22

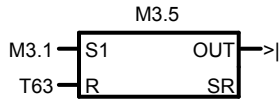

Network 23

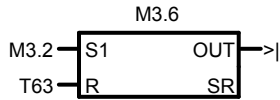

Network 24

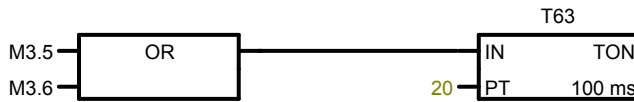

Network 25

Blazer links eiland 3

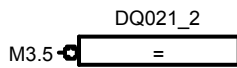

Symbol	Address	Comment
DQ021_2	V26.1	Symbol Output 2:Slave 21 - Digital (4I/4Q (St 7Hex))

Network 26

Blazer rechts eiland 3

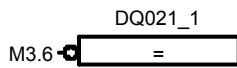

Symbol	Address	Comment
DQ021_1	V26.0	Symbol Output 1:Slave 21 - Digital (4I/4Q (St 7Hex))

Network 27

3/2 ventiel eiland 3 moet steeds actief zijn na start

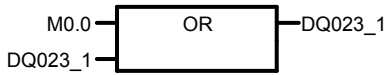

Symbol	Address	Comment
DQ023_1	V27.0	Symbol Output 1:Slave 23 - Digital (2I/2Q (St BHex))

Network 28

GRIJPEREILAND 3 NAAR TRANSPORTBAND BIJ START EN INDIEN ER EEN BLOKJE AANWEZIG IS OP HET EINDE VAN DE TRANSPORTBAND.

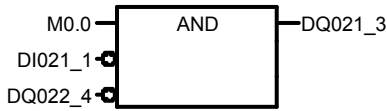

Symbol	Address	Comment
DI021_1	V10.0	Symbol Input 1:Slave 21 - Digital (4I/4Q (St 7Hex))
DQ021_3	V26.2	Symbol Output 3:Slave 21 - Digital (4I/4Q (St 7Hex))
DQ022_4	V27.7	Symbol Output 4:Slave 22 - Digital (4I/4Q (St 7Hex))

Network 29

1ste blokje op transportband onthouden

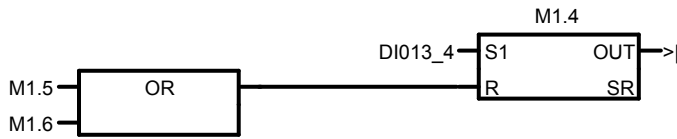

Symbol	Address	Comment
DI013_4	V6.3	Symbol Input 4:Slave 13 - Digital (2I/2Q (St BHex))

Network 30

als 1ste blokje metaal is

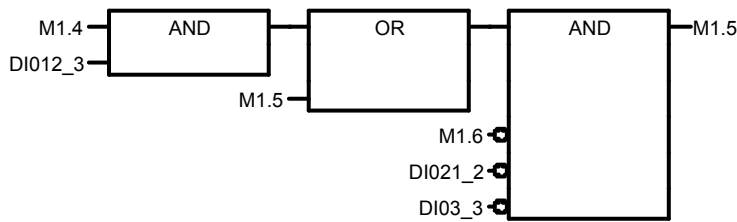

Symbol	Address	Comment
DI012_3	V6.6	Symbol Input 3:Slave 12 - Digital (2I/2Q (St BHex))
DI021_2	V10.1	Symbol Input 2:Slave 21 - Digital (4I/4Q (St 7Hex))
DI03_3	V1.2	Symbol Input 3:Slave 3 - Digital (4I/4Q (St 7Hex))

Network 31

als 1ste blokje rood of zwart is

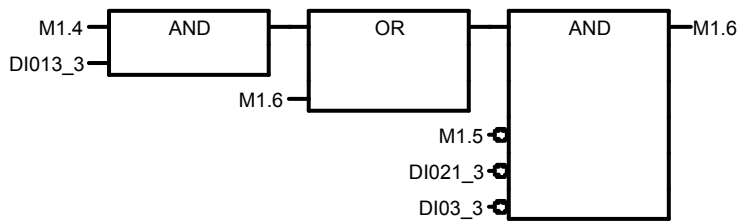

Symbol	Address	Comment
DI013_3	V6.2	Symbol Input 3:Slave 13 - Digital (2I/2Q (St BHex))
DI021_3	V10.2	Symbol Input 3:Slave 21 - Digital (4I/4Q (St 7Hex))
DI03_3	V1.2	Symbol Input 3:Slave 3 - Digital (4I/4Q (St 7Hex))

Network 32

geheugen 2de blokje

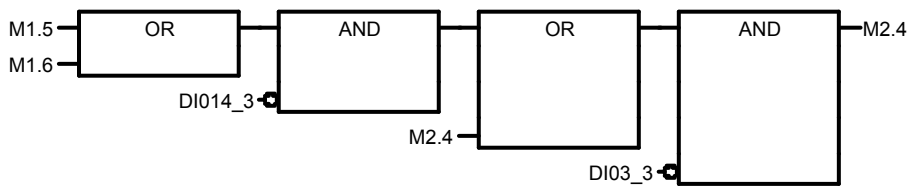

Symbol	Address	Comment
DI014_3	V7.6	Symbol Input 3:Slave 14 - Digital (2I/2Q (St BHex))
DI03_3	V1.2	Symbol Input 3:Slave 3 - Digital (4I/4Q (St 7Hex))

Network 33

2de blokje metaal

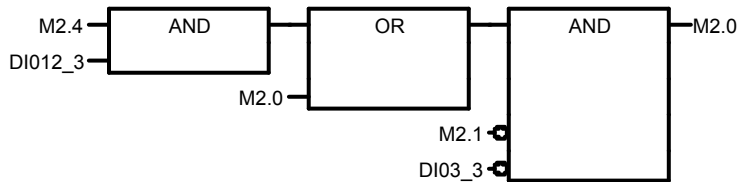

Symbol	Address	Comment
DI012_3	V6.6	Symbol Input 3:Slave 12 - Digital (2I/2Q (St BHex))
DI03_3	V1.2	Symbol Input 3:Slave 3 - Digital (4I/4Q (St 7Hex))

Network 34

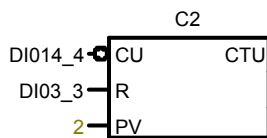

Symbol	Address	Comment
DI014_4	V7.7	Symbol Input 4:Slave 14 - Digital (2I/2Q (St BHex))
DI03_3	V1.2	Symbol Input 3:Slave 3 - Digital (4I/4Q (St 7Hex))

Network 35

2de blokje rood of zwart

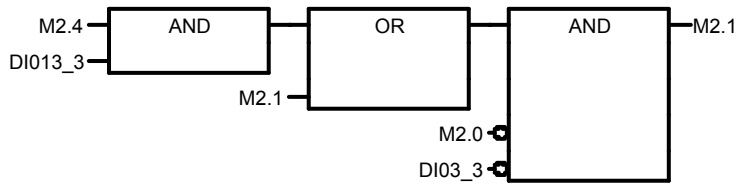

Symbol	Address	Comment
DI013_3	V6.2	Symbol Input 3:Slave 13 - Digital (2I/2Q (St BHex))
DI03_3	V1.2	Symbol Input 3:Slave 3 - Digital (4I/4Q (St 7Hex))

Network 36

2 de blokje metaal

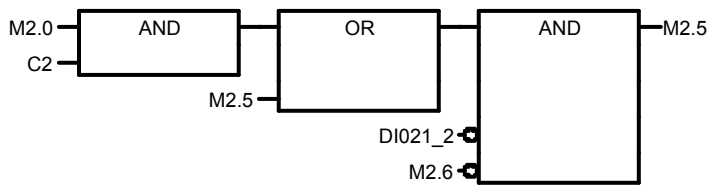

Symbol	Address	Comment
DI021_2	V10.1	Symbol Input 2:Slave 21 - Digital (4I/4Q (St 7Hex))

Network 37

2de blokje rood of zwart

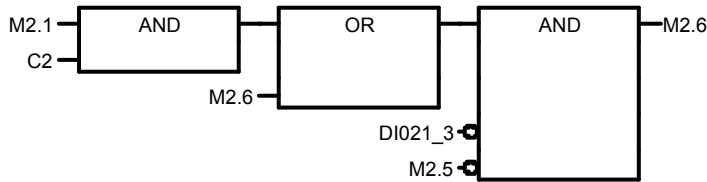

Symbol	Address	Comment
DI021_3	V10.2	Symbol Input 3:Slave 21 - Digital (4I/4Q (St 7Hex))

Network 38

metaal

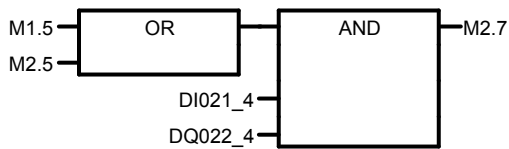

Symbol	Address	Comment
DI021_4	V10.3	Symbol Input 4:Slave 21 - Digital (4I/4Q (St 7Hex))
DQ022_4	V27.7	Symbol Output 4:Slave 22 - Digital (4I/4Q (St 7Hex))

Network 39

rood of zwart

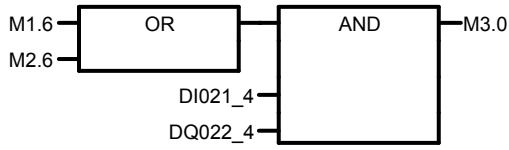

Symbol	Address	Comment
DI021_4	V10.3	Symbol Input 4:Slave 21 - Digital (4I/4Q (St 7Hex))
DQ022_4	V27.7	Symbol Output 4:Slave 22 - Digital (4I/4Q (St 7Hex))

Network 40

Cilinder naar sorteerbak

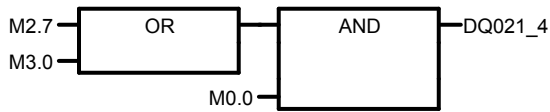

Symbol	Address	Comment
DQ021_4	V26.3	Symbol Output 4:Slave 21 - Digital (4I/4Q (St 7Hex))

Network 41

zuiger naar beneden

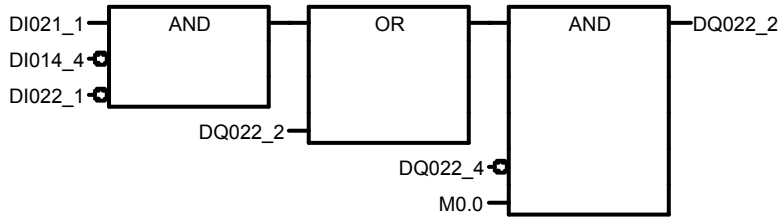

Symbol	Address	Comment
DI014_4	V7.7	Symbol Input 4:Slave 14 - Digital (2I/2Q (St BHex))
DI021_1	V10.0	Symbol Input 1:Slave 21 - Digital (4I/4Q (St 7Hex))
DI022_1	V11.4	Symbol Input 1:Slave 22 - Digital (4I/4Q (St 7Hex))
DQ022_2	V27.5	Symbol Output 2:Slave 22 - Digital (4I/4Q (St 7Hex))
DQ022_4	V27.7	Symbol Output 4:Slave 22 - Digital (4I/4Q (St 7Hex))

Network 42

Zuiger

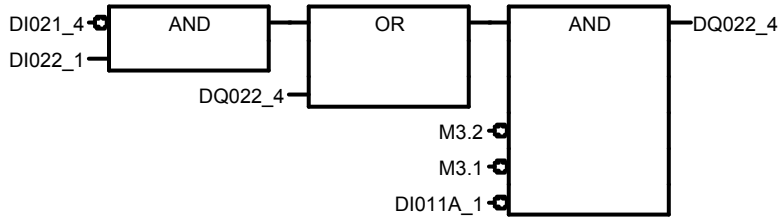

Symbol	Address	Comment
DI011A_1	V5.0	Symbol Input 1:Slave 11A - Digital (4I/3Q (AB 7Hex))
DI021_4	V10.3	Symbol Input 4:Slave 21 - Digital (4I/4Q (St 7Hex))
DI022_1	V11.4	Symbol Input 1:Slave 22 - Digital (4I/4Q (St 7Hex))
DQ022_4	V27.7	Symbol Output 4:Slave 22 - Digital (4I/4Q (St 7Hex))

Network 43

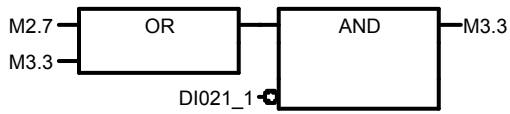

Symbol	Address	Comment
DI021_1	V10.0	Symbol Input 1:Slave 21 - Digital (4I/4Q (St 7Hex))

Network 44

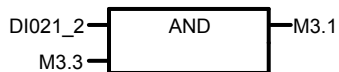

Symbol	Address	Comment
DI021_2	V10.1	Symbol Input 2:Slave 21 - Digital (4I/4Q (St 7Hex))

Network 45

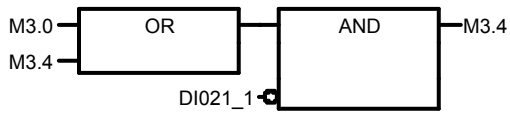

Symbol	Address	Comment
DI021_1	V10.0	Symbol Input 1:Slave 21 - Digital (4I/4Q (St 7Hex))

Network 46

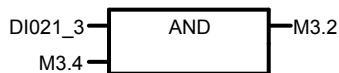

Symbol	Address	Comment
DI021_3	V10.2	Symbol Input 3:Slave 21 - Digital (4I/4Q (St 7Hex))

Network 47

cilinder naar boven

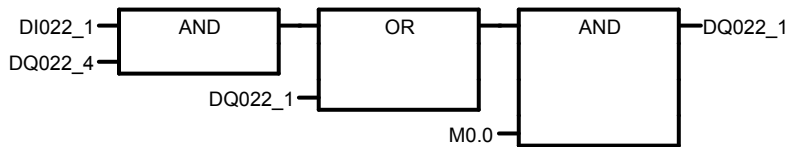

Symbol	Address	Comment
DI022_1	V11.4	Symbol Input 1:Slave 22 - Digital (4I/4Q (St 7Hex))
DQ022_1	V27.4	Symbol Output 1:Slave 22 - Digital (4I/4Q (St 7Hex))
DQ022_4	V27.7	Symbol Output 4:Slave 22 - Digital (4I/4Q (St 7Hex))

Network 48

Analoog signaal

Network 49

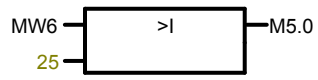

Network 50

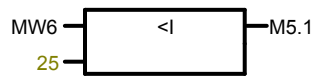

Network 51

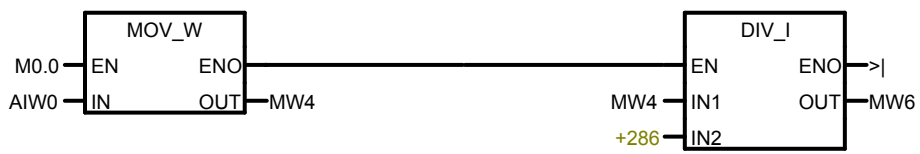

Block: SBR_0
Author:
Created: 04/05/2007 10:09:32 am
Last Modified: 05/29/2007 01:37:21 pm

Symbol	Var Type	Data Type	Comment
EN	IN	BOOL	
	IN		
	IN_OUT		
	OUT		
	TEMP		

SUBROUTINE COMMENTS

Network 1 Network Title

Network Comment

Block: INT_0
Author:
Created: 04/05/2007 10:09:32 am
Last Modified: 05/29/2007 01:37:21 pm

Symbol	Var Type	Data Type	Comment
	TEMP		
	TEMP		
	TEMP		
	TEMP		

INTERRUPT ROUTINE COMMENTS

Network 1 Network Title

Network Comment

Block: ASI0_CTRL
 Author: AS-Interface Wizard
 Created: 04/18/2007 06:07:49 pm
 Last Modified: 05/29/2007 01:37:21 pm

	Symbol	Var Type	Data Type	Comment
	EN	IN	BOOL	
		IN		
		IN_OUT		
LBO	Error	OUT	BYTE	error status
		OUT		
		TEMP		



This POU was generated by the AS-i Wizard for use with a module at position 0. This subroutine copies slave I/O data to and from V memory locations. This instruction should be called every scan and only be used once in the project.

Block: ASI0_READ
Author: AS-Interface Wizard
Created: 04/18/2007 06:07:49 pm
Last Modified: 05/29/2007 01:37:21 pm

	Symbol	Var Type	Data Type	Comment
	EN	IN	BOOL	
LB0	Bank	IN	BYTE	bank specification
LD1	DB_Ptr	IN	DWORD	address of starting location of 16 bytes
		IN		
		IN_OUT		
L5.0	Done	OUT	BOOL	command status
LB6	Error	OUT	BYTE	error status
		OUT		
		TEMP		



This POU was generated by the AS-i Wizard for use with a module at position 0. This subroutine is used to read data from CP.

Block: ASI0_WRITE
 Author: AS-Interface Wizard
 Created: 04/18/2007 06:07:49 pm
 Last Modified: 05/29/2007 01:37:21 pm

	Symbol	Var Type	Data Type	Comment
	EN	IN	BOOL	
LB0	Bank	IN	BYTE	bank specification
LD1	DB_Ptr	IN	DWORD	address of starting location of 16 bytes
		IN		
		IN_OUT		
L5.0	Done	OUT	BOOL	command status
LB6	Error	OUT	BYTE	error status
		OUT		
		TEMP		



This POU was generated by the AS-i Wizard for use with a module at position 0. This subroutine is used to write data to CP.